

6, 9 & 14 HP HORIZONTAL & VERTICAL LOG SPLITTERS

DEAR CUSTOMER

We take this opportunity of welcoming you as the owner of a Brent Smith Log Splitter. We want your machine to be the most efficient and productive piece of equipment you have. This manual will help you to achieve this objective.

The Brent Smith 6, 9 or 14 HP Horizontal & Vertical Log Splitters are a very mobile, hydraulically operated, petrol motor driven horizontal log splitters. The double acting hydraulic cylinder is operated by two handed controls for safe productive operation, ideally situated to allow the operator clear viewing of the machine functions, meeting relevant requirements and initiatives regarding Operator Safety and Machine Operation.



14hp Vertical

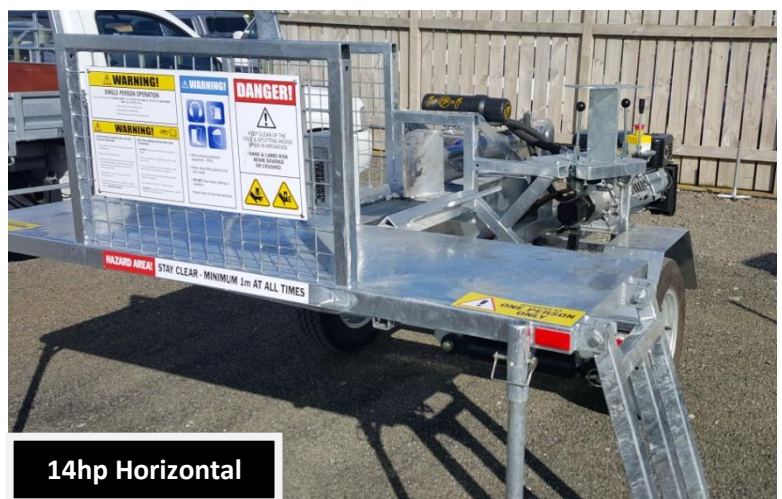

14hp Horizontal

INDEX

1.	RECEIVING YOUR NEW LOG SPLITTER	3
	Delivery.....	3
	Fuel and Oil Check	3
	Owner and Operator Responsibilities	3
	Location of Operations and Safety Manual.....	3
	Document Overview.....	4
2.	SAFETY	5
	Single Person Operation.....	5
	Personal Protective Equipment.....	6
	General Warnings.....	6
	Safe Handling of Fuel.....	7
	Operations Hazard Area	7
	Splitting-Zone Hazard Area.....	8
	Safety Signs.....	9
3.	OPERATION.....	11
	Prior to Starting	11
	Starting the Engine	11
	Stopping the Engine	12
	Safety Stop Button.....	12
	Two-Hand Control Lever System	12
	Log Lift Arm	13
	Operator Position	14
	Prior to Towing.....	14
4.	MAINTENANCE	15
	Splitter Blade	15
	Hydraulic Oil Filter	15
	Engine	15
	Hydraulic System and Components	15
5.	WARRANTY	16
	Manufacturer's Plate.....	16
	Machine Specifications.....	16
	Modifications.....	16
	Warranty.....	16
	Manufacturers Declaration	17
6.	SPARE PARTS LIST	18
	Spare Parts Diagrams	19

1. RECEIVING YOUR NEW LOG SPLITTER

Delivery

The log splitter is delivered fully assembled, however, before use carefully check the entire machine for transit damage and report any problems immediately.

Fuel and Oil Check

All new machines are delivered with oil filled to the recommended level and without fuel.

Owner and Operator Responsibilities

The safe operation and maintenance of your machine is very important to prevent any personal injury and/or equipment damage. Read and fully understand the following instructions before operating or carrying out maintenance.

The owner must make sure the log splitter remains safe to use. Always inspect before use and ensure the machine is maintained according to the manufacturer's recommendations.

Safety has been designed and manufactured into this equipment by the manufacturer, but only the people working with the machine can ensure a safe working environment.

MODIFICATIONS to the machine must not be performed without prior approval by Brent Smith Trailers. Modifications may negate your warranty. Only use Brent Smith Trailers approved parts.

The operator is responsible for **SAFE operation AT ALL TIMES.**

The Manual

This manual is designed for the log splitter owner and all operators. It describes how to operate the machine in the safest possible manner. It brings attention to the hazards of the machine and methods to avoid dangerous situations that may result in serious injury.





Location of Operations and Safety Manual



The OPERATIONS AND SAFETY MANUAL will arrive in the weatherproof canister. It is recommended this should be stored with the machine in the weatherproof canister at all times.



In this manual, all warnings and important information are highlighted by the following symbols

	Important information relating to the operation and use of the machine
NOTE	Used to convey additional information in relation to previous comments
 CAUTION	Used when there is the possibility of damage to the equipment or potential for premature equipment failure
 WARNING	Used to highlight the potential for injury or death
 DANGER	Used when there is the possibility of damage to the equipment AND/OR personal injury or death

Document Overview

ALL OPERATORS MUST READ THIS MANUAL BEFORE USING THE LOG SPLITTER
THE OPERATOR MUST ENSURE THOSE ASSISTING WITH THE LOADING/UNLOADING ALSO READ THIS MANUAL
FAILURE TO READ, UNDERSTAND AND FOLLOW THESE SAFETY PROCEDURES MAY RESULT IN EQUIPMENT DAMAGE, SERIOUS INJURY, OR DEATH
THE LOG SPLITTER MUST ONLY BE USED IN ACCORDANCE WITH THE INFORMATION AND INSTRUCTIONS PROVIDED IN THIS MANUAL
IN ADDITION TO READING THIS MANUAL, BECOME FAMILIAR WITH ESSENTIAL LOG SPLITTER SAFETY BY WATCHING THE SAFETY VIDEOS AVAILABLE ON THE COMPANY WEBSITE (ALSO AVAILABLE FROM HIRING COMPANIES) visit www.bst_brentsmithtrailers.logsplitter/safety/etc 

Use caution while operating the machine and follow all safety procedures. Treat this equipment with respect and service it regularly.

2. SAFETY

Single Person Operation

	<p><u>Single-Person Operation ONLY</u></p> <p>Due to the high risk of serious injury, the machine must ONLY be OPERATED by one person. OPERATED means:</p> <ul style="list-style-type: none">• Placing logs in the splitting-zone• Operating the Control Levers (to actuate the splitting wedge)• Removing split pieces from the splitting-zone
---	---



NOTE	The barrier guards and layout of the machine have been designed to inhibit more than one person performing these tasks
-------------	--

	<p>KEEP HANDS and LIMBS clear of the splitting-zone</p> <p>DO NOT hold or support the log while it is being split</p> <p>DO NOT allow anyone else to support the log while it is being split</p> <p>DO NOT allow another person to remove logs directly from the splitting zone</p> <p>DO NOT tamper with the Motor Speed control</p> <p>DO NOT tamper with the Hydraulic Pressure Relief Valve</p> <p>DO NOT operate the machine unless all people are clear of the splitting-zone hazard area</p>
---	---

NOTE	It is considered safe for another person to assist the operator by loading logs onto the table and removing them from the table once they have been cleared from the splitting-zone
-------------	---

Be Prepared

It is recommended you have available a fire extinguisher, medical kit and phone for emergencies whilst conducting any work with the log splitters.

DO YOU HAVE A FULLY EQUIPPED MEDICAL KIT?	
DO YOU HAVE A FIRE EXTINGUISHER AVAILABLE?	
CAN YOU MAKE AN EMERGENCY CALL?	Dial 111

Personal Protective Equipment

Appropriate personal protective equipment (PPE) is required for the operator and persons assisting with loading/unloading operations.

- Always wear hearing protection
- Always wear safety footwear
- Always use eye protection - Full-face shields are recommended

Protect your hands - tight-fitting gloves are recommended



WARNING

DO NOT wear loose clothing or jewellery that might get caught in moving parts

Keep loose and long hair tied back or covered

General Warnings



DANGER

Splitting mechanism is very **POWERFUL** and **MOVES QUICKLY**

LOG SPLITTERS can cause **SERIOUS INJURY!**

Hands and limbs risk being **CRUSHED** or **SEVERED**.



WARNING

DO NOT use the log splitter for any purpose other than cutting wood

Cut along the wood grain **ONLY**



DANGER

DO NOT cut across the grain - Cutting across the grain may cause wood pieces to be flung from the machine



WARNING

OPERATION OF THE LOG SPLITTER MUST NOT BE PERFORMED BY PERSONS UNDER THE INFLUENCE OF ALCOHOL, DRUGS, MEDICATIONS OR ANY CHEMICALS CAPABLE OF IMPAIRING THE ABILITIES OF THAT PERSON



WARNING

Not to be operated by people under the age of **16**

Safe Handling of Fuel

⚠ DANGER

Fuel is highly flammable especially on hot surfaces - HANDLE WITH CARE!

NEVER refuel while the Engine is running



1. Stop the Engine and allow it to cool before refueling
2. Use a funnel or nozzle to avoid spillage
3. Replace gasoline cap securely and clean up spilled fuel before restarting
4. Use an approved fuel storage container

Operations Hazard Area

⚠ DANGER

PUBLIC SAFETY WARNING

Keep all bystanders outside of the **Operations Hazard Area**
Always check the area for children!

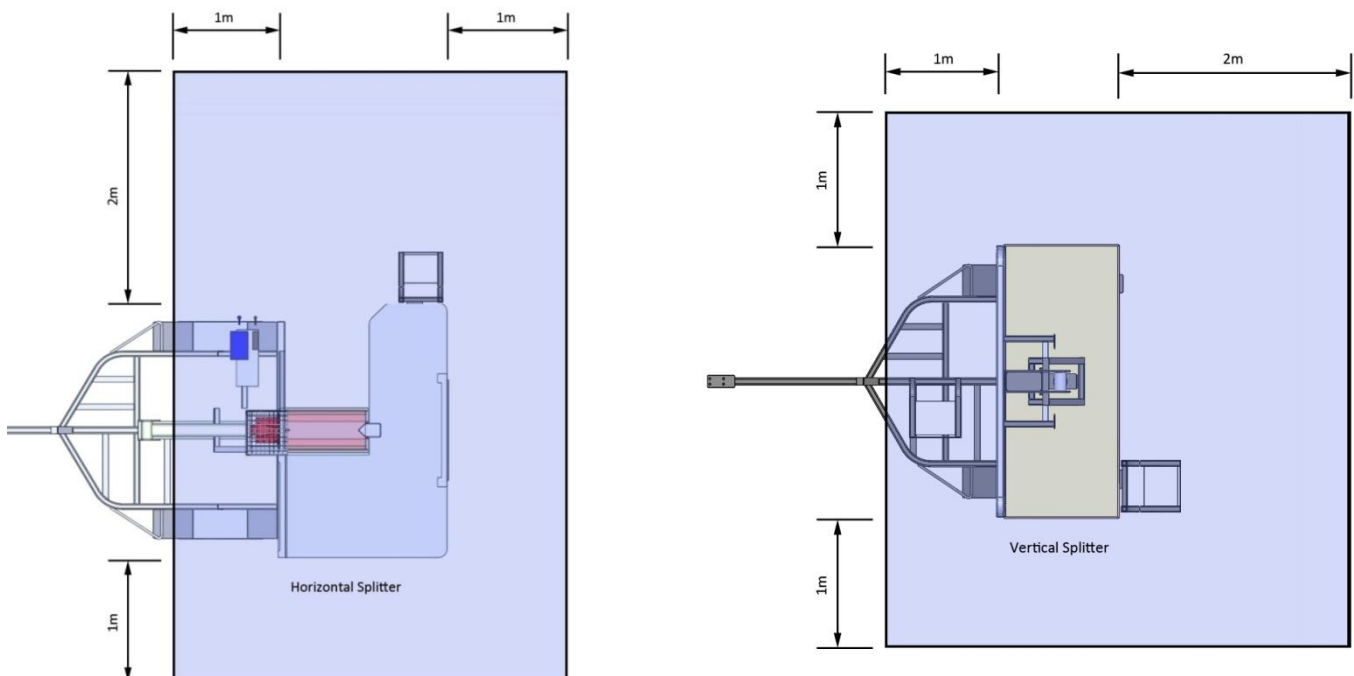

Figure X. Operations hazard area - Horizontal and Vertical log splitters

Splitting-Zone Hazard Area

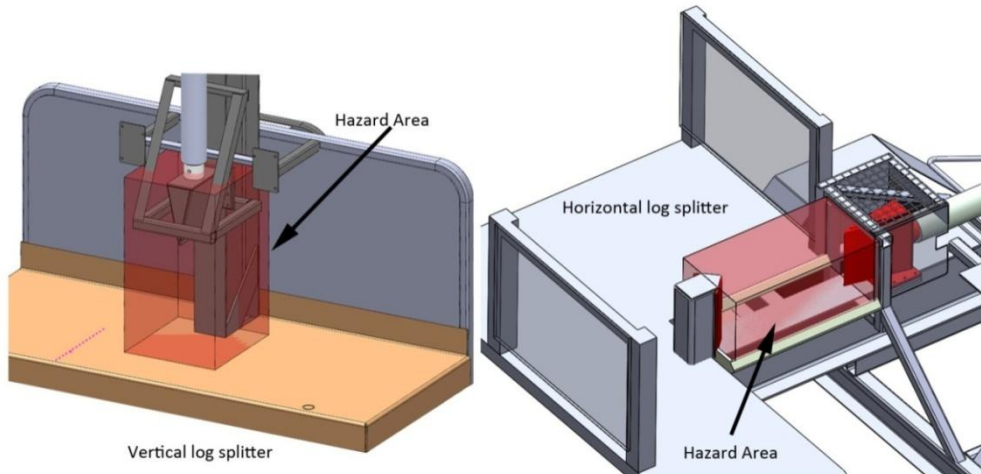

Figure Y. Splitting-zone hazard area

⚠ DANGER

KEEP HANDS and LIMBS clear of the **splitting-zone hazard area** on both the cutting and return stroke

NEVER reach or bend over the splitter-zone to pick up a log

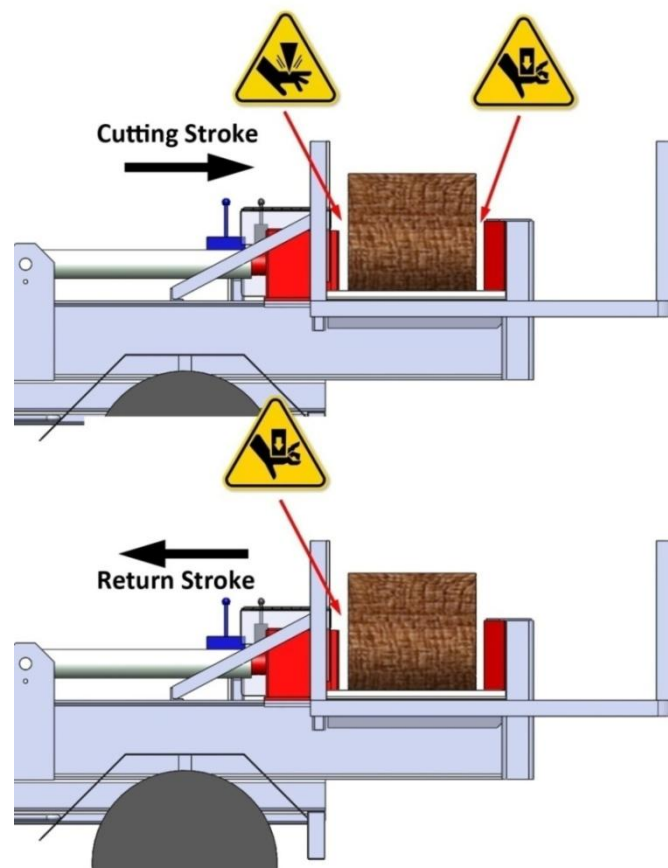



Figure Z. Severing and crushing hazards

⚠ WARNING

Never leave the Engine running when unattended - shut the machine down even if unattended for a short period

 WARNING	<p>Exhaust gases are poisonous - DO NOT run the Engine indoors or in an enclosed area</p> <p>Always ensure there is adequate ventilation</p>
--	--

Safety Signs

All operators must familiarise themselves with the “DANGER” and "WARNING" signs shown in this section. Some log splitters may have additional safety signs that are not described here. All safety signs affixed to the machine must be identified, read and understood. These signs have been designed for maximum durability and legibility.

	<p>Safety Sign Maintenance</p> <p>Safety Signs on the log splitter safety are considered safety equipment. They must be maintained just as any other safety device. Safety signs must be kept clean and legible to the operator, operational personnel, and bystanders.</p>
---	--

<h2>NOTES</h2>	<p>If a sign becomes damaged or illegible, replace it at your earliest opportunity</p> <p>If the machine is repaired or repainted, replace all signs before putting back into service</p> <p>Replacement signs are available from Brent Smith Trailers Limited</p>
----------------	--

The following Table shows the Safety Signs used on Brent Smith Trailers log splitters, along with an explanation of their purpose, location, and the normal quantity used on each machine.

Label Name: EMERGENCY STOP		
Part #	BST0101	
Function	Identify location	
Location	Beside Emergency Stop button	
Quantity	1	

Label Name: SAFETY BOARD		
Part #	BST0102	
Function	List Safety Instructions	
Location	Safety Mesh Grill	
Quantity	1	

Label Name: HAZARD 1M CLEARANCE - VERTICAL		
Part #	BST0104	
Function	Warning - Bystander safety zone	
Location	Sides of Log Splitter	
Quantity	2	

Label Name: HAZARD 2M CLEARANCE - VERTICAL		
Part #	BST0105	
Function	Warning - Bystander safety zone	
Location	Rear of Log Splitter	
Quantity	1	

Label Name: HAZARD 1M CLEARANCE - HORIZONTAL		
Part #	BST0106	
Function	Warning - Bystander safety zone	
Location	Side & Rear of Log Splitter	
Quantity	2	

Label Name: CONTROL DIRECTION		
Part #	BST0107	
Function	Direction from controls for splitting wedge	
Location	Beside each Controller	
Quantity	2	

Other Signage

Label Name: MANUFACTURERS LABEL		
Part #	BST0103	
Function	Give Manufacturer contact details	
Location	Light Board	
Quantity	1	

3. OPERATION

Prior to Starting

1. Disconnect the Log Splitter from the towing vehicle
2. Check that the ground is level and there is adequate ventilation for exhaust fumes
3. Lower the stabiliser legs and level the machine. If necessary, use a large flat support pad under the stabiliser feet to prevent the legs from sinking. Ensure the locking screws are secured firmly.
4. Check for damage and loose parts - check the condition of the Safety Stop button
5. Check fuel, engine oil level and hydraulic oil level
6. Wear personal protective equipment



WARNING

AVOID SLIPS!

DO NOT operate on a wet, muddy or greasy surface!

Starting the Engine



CAUTION

AVOID flooding the engine!

Check the Safety Stop button has been released before starting



1. Check no one is near the splitting-zone and bystanders are clear of the machine (outside the operations hazard area)
2. Check the Safety Stop button is released (twist to release)
3. Turn the Fuel Switch to the ON position (Fig 1)
4. Turn the Engine Switch to the ON position (Fig 2)
5. If the engine is cold, close the Choke Lever (Fig 3)
6. Start the Engine using the Pull Cord (Fig 4) - release once the Engine is running.
7. Once the machine is running properly, return the Choke Lever to the OPEN position.



Fig 1 - Fuel Switch



Fig 2 - Engine switch



Fig 3 - Choke Valve



Fig 4 - Start Cord

Stopping the Engine

1. Turn the Engine switch to the OFF position (Fig 2)

	<p>ENGINE speed and Hydraulic System Pressure have been factory set as a safety measure and to ensure the longevity of the machine,</p> <p>DO NOT tamper with the Motor Speed control</p> <p>DO NOT tamper with the Hydraulic Pressure Relief Valve</p>
---	---

Safety Stop Button

The SAFETY STOP BUTTON is a safety device designed to remove all power from the log splitter when activated and prevent unexpected start up.

Activating the Safety Stop will turn the Engine OFF. If the wedge is moving, activating the Safety Stop will not bring the wedge to an immediate stop (if the safety stop is activated while the wedge is moving at full speed, the wedge will travel approximately 150mm before coming to a complete stop).

Safety Function Check - Safety Stop Button

Before starting splitting operations, check that the SAFETY STOP BUTTON functions correctly.

1. While the Engine is OFF. Check that the Safety Stop Button moves freely. Press the Safety Stop Button and check that it locks in the ON position
2. Release the Safety Stop Button to allow the engine to start
3. Start the Engine and keep it running for at least 5 seconds
4. Press the Safety Stop Button and check the Engine shut downs

	<p>DO NOT continue to use if the Engine fails to shut down after pressing the Safety Stop Button</p> <ul style="list-style-type: none">• Shut the machine down using the ON/OFF switch at the engine.• Contact the Manufacturer
---	--

Two-Hand Control Lever System

The TWO-HAND CONTROL LEVER system is a safety device. It is designed to ensure that when the splitting wedge is moving the operator has both hands and upper limbs clear of the splitting-zone.

	<p>ALWAYS use two hands on the controls</p> <p>DO NOT modify the control levers or use an extension device or tool to avoid two-hand operation</p>
---	--

Safety Function Checks - Control Lever System

The control lever system is designed to ensure the splitting wedge stops immediately when either or both of the levers are released.

1. Start the machine and move the splitting wedge by actuating both levers at the same time
2. Release the left-hand control lever and check that the splitting wedge stops immediately
3. Repeat with the right-hand control lever
4. Repeat by releasing both levers at the same time



DO NOT continue to use the machine if the splitting wedge fails to stop when performing any of the above safety checks.

Contact the Manufacturer for instructions on repair or replacement

Log Lift Arm

The Lift Arm mechanism, provided for lifting logs onto the machine, is powered by a separate hydraulic cylinder. Multiple logs can be placed on the arm for lifting.



LOG ON LIFT ARM FIG A



LIFT ARM LEVER FIG B



CLEVIS PIN & RETAINING CLIP FIG C



STOWAGE RETAINING CLIP FIG D



SECURING / REMOVING THE HYDRAULIC CYLINDER TO STOWAGE BRACKET WITH CLEVIS PIN FIG E

Set Up

1. Disconnect the Hydraulic Cylinder from its Stowage Bracket (Fig E). Remove the Retaining Clip. Remove the Clevis Pin and position the Cylinder so it can move freely.
2. Remove the Retaining Clip and disconnect the Lift Arm from its Stowed Position (Fig D).
3. Lower the Lift Arm
4. Turn the Engine ON
5. Connect the Hydraulic Cylinder to the Lift Arm Bracket. Use the Lift Arm Control Lever (Fig B) to move Hydraulic Cylinder and align the Clevis with the hole on the Lift Arm Bracket
6. Secure the Hydraulic Cylinder. Insert the Clevis Pin and Retaining Clip (Fig E)

Operation

1. The Lift Arm Hydraulic Cylinder will only operate when the Engine is running
2. Place log(s) onto the Lift Arm (Fig A)
3. Raise and Lower using the Lift Arm Control Lever (Fig B)

Stowage

1. Disconnect the Hydraulic Cylinder from the Lift Arm Bracket. Remove Retaining Clip and Clevis Pin (Fig E)
2. Raise the lift arm into the Stowed Position and secure with the Retaining Clip (Fig D)
3. Adjust the position of the Hydraulic Cylinder so it can be re-secured to its Stowage Bracket. Insert Clevis Pin and Retaining Clip (Fig C)

Operator Position

The operator should position themselves facing the two handed controls. This is part of safe use of the machine as:

1. It allows for full visual coverage of the hazard zone
2. It allows the operator to check no one else is at risk of injury
3. It prevents others from loading logs into the splitting-zone
4. It ensures the operator's body, hands and limbs are clear of the machine hazards when operating the controls
5. It prevents logs from falling onto the lower limbs of the operator or those assisting with loading/unloading

Prior to Towing

1. Fully raise the stabiliser legs and ensure they are stowed and secure. Ensure the locking screws are secured firmly
2. Ensure the Log Lifter is raised, stowed and secure
3. Check that the fuel cap is secure
4. Secure the trailer to the towing vehicle and ensure the safety chain is connected correctly

4. MAINTENANCE

Perform all recommended maintenance procedures before using the log splitter.

- a) Check the entire machine for damaged, worn or broken parts. Replace any defective parts before using the machine.

Splitter Blade (Fig 3)

- a) Inspect the wear strip (1) the blade base (2) main beam (3) and bottom plate (4) for wear and damage.
- b) Check the edge of the blade (5) and sharpen if required.

Fig 3 - Splitter Blade Maintenance

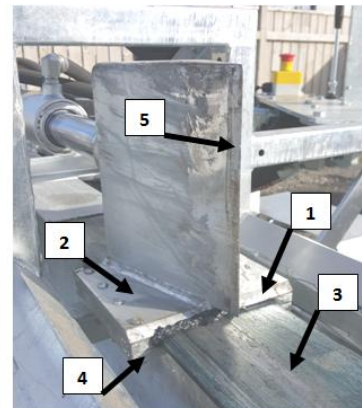

Hydraulic Oil Filter (Fig 4).

- a) The hydraulic filter is located in the top of the hydraulic tank.
- b) To service the filter undo the three bolts (1) on top plate, Remove the top plate (2), remove the filter element and fit the new element.
- c) Change the hydraulic filter element every 500 hours or every six months.
- d) Examine the used filter element for any unusual contamination, if any metal particles are found check the system for the cause or contact the service agent. Disconnect the filter cartridge and replace.



Fig 4 – Hydraulic Filter

Engine

The engine maintenance is fully covered in the engine instruction handbook delivered with the unit. However the following list of instructions are the minimum required for daily maintenance.

- a) Check the engine oil and fill if required, do not overfill.
- b) Check the fuel level and fill if required, do not overfill the tank.
- c) Check all hoses for leaks. Check joints, wires, cables and leads for damage and wear, replace immediately if damage is found.
- d) Check the engine for loose parts, do not start the engine with insecure and loose parts.

Hydraulic System and Components

Daily check all hydraulic hoses for leaks, wear, cracking, kinks and chaffing. Replace any defective hose immediately.

5. WARRANTY

Manufacturer's Plate

Your serial and Hydraulic Pump Number are located on the manufacturers plate.

When ordering any parts always quote the machine serial number. Use the cylinder number as well as the machine number when ordering parts for the cylinder.

Machine Specifications

1. Number of operators	One operator ONLY		
1. Maximum log length	450mm		
2. Maximum log diameter	800mm		
3. Maximum cutting stroke	500mm		
4. Energy input	Model		
	6	9	14
	6HP	9HP	14HP
5. Maximum hydraulic system Pressure	2400 PSI	2800 PSI	3000 PSI
6. Over-pressure protection	YES	YES	YES
7. Over-pressure safety valve setting	2400 PSI	2800 PSI	3000 PSI
8. Maximum free speed of Splitting Wedge	200mm per second	250mm per second	300mm per second
9. Maximum cutting force	400kgf	800kgf	1200kgf
10. Duty	100%		
11. Fuel Type	91 Unleaded		
12. Fuel Capacity	3.2 litres	5.6 litres	6.8 litres
13. Oil Type	SAE 10W-30		
14. Oil Capacity	.6 litre	1 litre	1.2 litres

Modifications

Modifications to the machine must not be performed without prior approval by Brent Smith Trailers. Only use Brent Smith Trailers approved parts.

DO NOT alter or modify any safety device!	
	WARNING All safety devices must be inspected, tested and maintained in proper working condition.

Warranty

Brent Smith Trailers warrants new products sold by it to be free from defects in material and workmanship for a period of twelve months after delivery to the initial user buyer. This warranty is for the replacement or repair of any part found to be defective during the warranty period. This warranty excludes any transport costs incurred by Brent Smith Trailers in giving effect to the warranty and specifically excludes all normal maintenance costs.

Replacement parts provided under the terms of this warranty are covered for the remainder of the warranty period applicable to the product in which they are installed as if such parts were original components of that product. Unauthorised repairs or modifications negate this warranty.

Manufacturers Declaration

This statement covers the following products

- i. Horizontal Log Splitters (6HP, 9HP & 14HP)
- ii. Vertical Log Splitters (9HP & 14HP)

These products are designed and manufactured in accordance with the following:

Work Cover New South Wales Wood Splitters Industry Safety Standard: 2008

EN609-1:1999 Agricultural and Forestry Machinery - Safety of Log Splitters - Part 1: Wedge Splitters + A2:2009

EN574 Two-Handed Controls, excluding clause 5.7.1

Manufacturer

Name M&M LOG SPLITTERS Manufactured by Brent Smith Trailers Limited

Address 66 Nannestad Line, PO BOX 67, Bunnythorpe

Phone 0800 509 777

Date 8 December 2015

Signed

A handwritten signature in black ink, appearing to be 'Brent Smith', is written over the date field.

6. SPARE PARTS LIST

All Log Splitter parts listed can be ordered directly from Brent Smith Trailers.

	LOCATION	PART #	DESCRIPTION	QTY	COMMENTS
1	BASE	TROGAN	SUPPORT, Towbar	1	
2	BASE		TOW COUPLING	1	
3	BASE		SAFETY CHAIN	1	
4	BASE		LIGHT PLUG	1	
5	BASE		REAR SUPPORT LEGS & STOWAGE PIN	2	
6	BASE		LEAF SPRINGS AND BOLTS SET	2	
7	BASE		U BOLTS, PLATES AND NUT SET	2	
8	BASE		AXLE	1	
9	BASE	PT1010	BEARING, Kit (Trogan)	1	
10	BASE	13"	WHEEL	2	
11	BASE	175x13	TYRE	2	
12	CONTROL BANK	LS 3000	VALVE, Control	1	
13	CONTROL BANK	LS 3000	SEAL KIT, Control Valve	1	
14	CONTROL BANK	LS 3000	LEVER & KNOB	1	
15	CONTROL BANK	14	HOSE KIT	1	
16	ENGINE		RECOIL ASSEMBLY, Start	1	Refer Engine Manual P/N
17	ENGINE	EX40DU	ENGINE	1	Refer engine manual P/N
18	ENGINE		SPARK PLUG	1	Refer engine manual P/N
19	ENGINE		FILTER, Air	1	Refer Engine Manual P/N
20	ENGINE	14	COUPLING, Pump	1	
21	ENGINE	CJ 3032	HOUSING, Coupling	1	
22	RAM	STANDARD	PIN, RAM PIN	1	
23	RAM	3x2x457	CYLINDER, Hydraulic	1	
24	RAM		SEAL KIT, RAM	1	Use S/N on cylinder for P/N
25	RAM	STANDARD	BLADE ASSEMBLY	1	
26	RAM	14	PLATE, Wear, Side	1	
27	RAM	14	PLATE, Wear, Bottom	1	
28	HYD. OIL TANK	F150AN	PUMP	1	
29	HYD. OIL TANK	CR171C10R	FILTER ASSEMBLY, Hydraulic Oil	1	
30	HYD. OIL TANK		BREATHER CAP	1	
31	HYD. OIL TANK	JP1057	RETURN HOSE FITTING	1	
32	LABELS	BST0101	SAFETY STOP	1	
33	LABELS	BST0102	SAFETY BOARD	1	
34	LABELS	BST0103	MANUFACTURERS NAME	1	
35	LABELS	BST0104	HAZARD 1 M CLEANANCE VERT	2	
36	LABELS	BST0105	HAZARD 2M CLEARANCE VERT	1	
37	LABELS	BST0106	HAZARD 1M CLEARANCE HORIZ	2	
38	LABELS	BST0107	BLADE DIRECTION	1	
39	OTHER		LIFT ARM - CLEVIS PIN & CLIP	1	
40	OTHER		LIFT ARM - STOWAGE CLIP	1	
41	OTHER		UMBRELLA	1	Optional extra
42	OTHER		GRATED TABLE	1	Optional extra
43	OTHER		INSTRUCTIONS & SAFETY MANUAL	1	
44	OTHER		DOCUMENT HOLDER	1	
45	OTHER		TRAINING DVD	1	

Spare Parts Diagrams

